

**Agri-Fab™**

**OWNERS  
MANUAL**

**MODEL NO.  
45-02162**

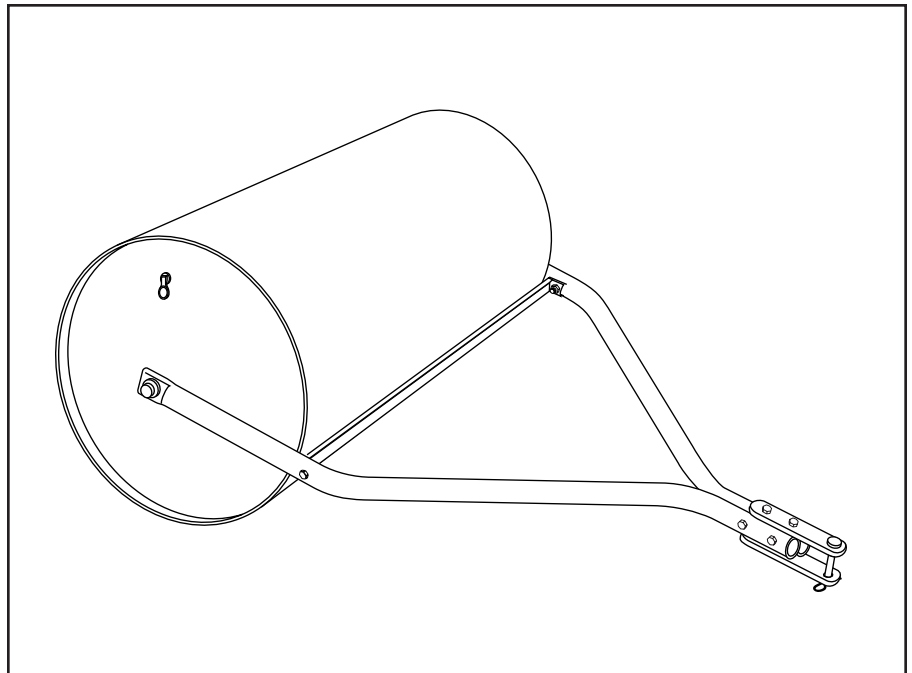

**H.D. LAWN ROLLER**  
(24" Dia. x 48" Wide)

**SAFETY PRECAUTIONS**

1. **Never** attach a garden hose to the fill/drain hole when filling. Dangerous pressure build up could occur inside roller.
2. Do not fill roller to maximum weight without checking capability of vehicle to safely pull and stop.
3. Never use roller up and down hills; always work across hills and slopes.
4. Use caution when turning, slowing or stopping.
5. Always drain roller to keep from freezing.

**SPECIFICATIONS:**

**Roller Drum:** 24" Dia. x 48" Wide Welded Steel  
**O.A. Width:** Approximately 52"  
**Bearings:** 1" I.D., Replaceable  
**Tow Hitch:** Std. Pin Type - 1/2" Hole  
**Weight w/ Water:** Up to 910 Lbs. Filled with Water  
(Note: May be filled with sand)  
**Approx. Sh. Wt.:** Approximately 165 Lbs.

## ASSEMBLY INSTRUCTIONS

(SEE ILLUSTRATION BELOW)

1. Assemble bearings (Ref. 5) into hitch tubes (Ref. 3) so that bearing flange is against outside of hitch tube. (You may need to place a block of wood against bearing and carefully tap with a hammer.)
2. Place hitch tubes (Ref. 3) onto both ends of roller shaft. Assemble a flat washer (Ref. 6) onto each end of roller shaft and secure with two cotter pins (Ref. 12).
3. Assemble scraper bar (Ref. 2) to hitch tubes (Ref. 3) using two hex bolts (Ref. 9) and hex lock nuts (Ref. 10). **Do not tighten yet.**
4. Assemble ends of hitch tubes (Ref. 3) together using two hex bolts (Ref. 7) and hex lock nuts (Ref. 10). **Do not tighten yet.**
5. Assemble hitch brackets (Ref. 4) to hitch tubes (Ref. 3) using two hex bolts (Ref. 8) and hex lock nuts (Ref. 10). **Do not tighten yet.**
6. **Tighten** bolts and nuts starting with scraper bar (Ref. 2), then ends of hitch tubes (Ref. 3), and finally hitch brackets (Ref. 4).
7. Install hitch pin (Ref. 13) through hitch brackets (Ref. 4) and secure with hair cotter pin (Ref. 14).
8. Adjust plug (Ref. 11) size by twisting handle. Lock plug in roller drum by flipping handle down.

### ADJUST SIZE

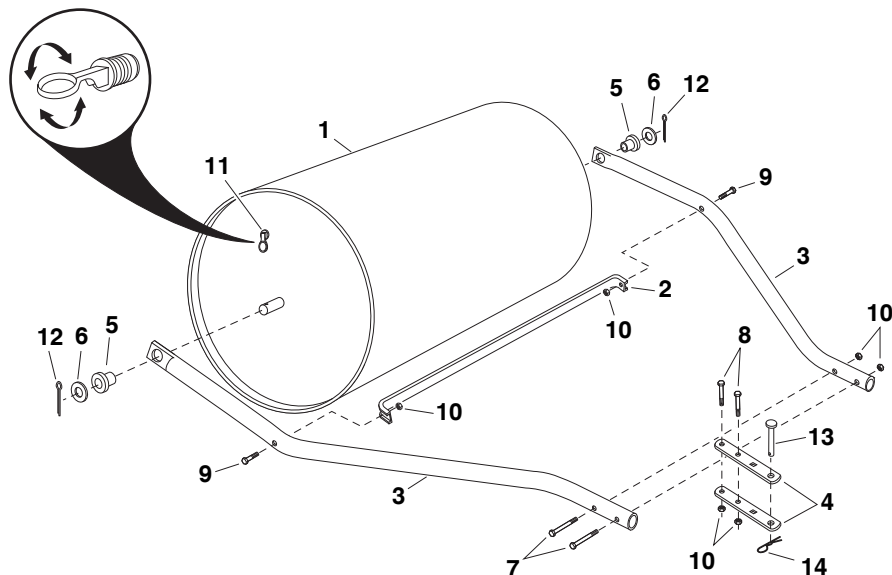

Ref. No.	Part No.	Qty.	Description	Ref. No.	Part No.	Qty.	Description
1	-----	1	Roller Drum (Not sold separately)	8	43224	2	Hex Bolt, 5/16-18 x 2-1/4"
2	24868	1	Scraper Bar	9	43084	2	Hex Bolt, 5/16-18 x 1-3/4"
3	48376	2	Hitch Tube	10	47810	6	Hex Lock Nut, 5/16-18
4	24192	2	Hitch Bracket	11	49467	1	Plug, Lawn Roller
5	43632	2	Bearing, Plastic	12	43501	2	Cotter Pin, 5/32" x 1-1/2"
6	43528	2	Flat Washer, 1"	13	47623	1	Hitch Pin
7	46782	2	Hex Bolt, 5/16-18 x 3"	14	43343	1	Hair Cotter Pin 1/8"

### REPAIR PARTS

Agri-Fab, Inc.  
303 West Raymond  
Sullivan, IL. 61951  
217-728-8388  
www.agri-fab.com

**SpeedPart** the fastest way to purchase parts [www.speedpart.com](http://www.speedpart.com)